

CBCS SCHEME

USN

--	--	--	--	--	--	--	--	--	--

15MAT31

Third Semester B.E. Degree Examination, Dec.2019/Jan.2020 Engineering Mathematics – III

Time: 3 hrs.

Max. Marks: 80

Note: Answer any FIVE full questions, choosing ONE full question from each module.

Module-1

- 1 a. Obtain the Fourier expansion of the function $f(x) = x$ over the interval $(-\pi, \pi)$. Deduce that $\frac{\pi}{4} = 1 - \frac{1}{3} + \frac{1}{5} - \frac{1}{7} + \dots$ (08 Marks)
- b. The following table gives the variations of a periodic current A over a certain period T:

t (sec)	0	T/6	T/3	T/2	2T/3	5T/6	T
A (amp)	1.98	1.30	1.05	1.30	-0.88	-0.25	1.98

Show that there is a direct current part of 0.75amp in the variable current and obtain the amplitude of the first harmonic. (08 Marks)

OR

- 2 a. Obtain the Fourier series for the function $f(x) = 2x - x^2$ in $0 \leq x \leq 2$. (06 Marks)
- b. Represent the function $f(x) = \begin{cases} x, & \text{for } 0 < x < \pi/2 \\ \pi/2, & \text{for } \pi/2 < x < \pi \end{cases}$ in a half range Fourier sine series. (05 Marks)
- c. Determine the constant term and the first cosine and sine terms of the Fourier series expansion of y from the following data:

x°	0	45	90	135	180	225	270	315
y	2	3/2	1	1/2	0	1/2	1	3/2

(05 Marks)

Module-2

- 3 a. Find the complex Fourier transform of the function $f(x) = \begin{cases} 1 & \text{for } |x| \leq a \\ 0 & \text{for } |x| > a \end{cases}$ Hence evaluate $\int_0^\infty \frac{\sin x}{x} dx$. (06 Marks)
- b. If $\bar{u}(z) = \frac{2z^2 + 3z + 12}{(z-1)^4}$ show that $u_0 = 0$ $u_1 = 0$ $u_2 = 2$ $u_3 = 11$. (05 Marks)
- c. Obtain the Fourier cosine transform of the function $f(x) = \begin{cases} 4x, & 0 < x < 1 \\ 4-x, & 1 < x < 4 \\ 0, & x > 4 \end{cases}$ (05 Marks)

OR

- 4 a. Obtain the Z-transform of $\cos n\theta$ and $\sin n\theta$. (06 Marks)
- b. Find the Fourier sine transform of $f(x) = e^{-|x|}$ and hence evaluate $\int_0^{\infty} \frac{x \sin mx}{1+x^2} dx$ $m > 0$. (05 Marks)
- c. Solve by using Z-transforms $y_{n+2} + 2y_{n+1} + y_n = n$ with $y_0 = 0 = y_1$. (05 Marks)

Module-3

- 5 a. Fit a second degree parabola $y = ax^2 + bx + c$ in the least square sense for the following data and hence estimate y at $x = 6$. (06 Marks)

x	1	2	3	4	5
y	10	12	13	16	19

- b. Obtain the lines of regression and hence find the coefficient of correlation for the data:

x	1	3	4	2	5	8	9	10	13	15
y	8	6	10	8	12	16	16	10	32	32

- c. Use Newton-Raphson method to find a real root of $x \sin x + \cos x = 0$ near $x = \pi$. Carry out the iterations upto four decimal places of accuracy. (05 Marks)

OR

- 6 a. Show that a real root of the equation $\tan x + \tanh x = 0$ lies between 2 and 3. Then apply the Regula Falsi method to find third approximation. (06 Marks)
- b. Compute the coefficient of correlation and the equation of the lines of regression for the data:

x	1	2	3	4	5	6	7
y	9	8	10	12	11	13	14

- c. Fit a curve of the form $y = ae^{bx}$ for the data:

x	0	2	4
y	8.12	10	31.82

- 7 a. From the following table find the number of students who have obtained:
- Less than 45 marks
 - Between 40 and 45 marks.

Marks	30-40	40-50	50-60	60-70	70-80
Number of students	31	42	51	35	31

- b. Construct the interpolating polynomial for the data given below using Newton's general interpolation formula for divided differences and hence find y at $x = 3$.

x	2	4	5	6	8	10
y	10	96	196	350	868	1746

- c. Evaluate $\int_0^1 \frac{x}{1+x^2} dx$ by Weddle's rule. Taking seven ordinates. Hence find $\log_e 2$. (05 Marks)

OR

- 8 a. Use Lagrange's interpolation formula to find $f(4)$ given below. (06 Marks)

x	0	2	3	6
f(x)	-4	2	14	158

- b. Use Simpson's $3/8^{\text{th}}$ rule to evaluate $\int_1^4 e^{1/x} dx$. (05 Marks)

- c. The area of a circle (A) corresponding to diameter (D) is given by

D	80	85	90	95	100
A	5026	5674	6362	7088	7854

Find the area corresponding to diameter 105 using an appropriate interpolation formula.

(05 Marks)

Module-5

- 9 a. Evaluate Green's theorem for $\oint_c (xy + y^2) dx + x^2 dy$ where c is the closed curve of the region bounded by $y = x$ and $y = x^2$. (06 Marks)
- b. Find the extremal of the functional $\int_a^b (x^2 + y^2 + 2y^2 + 2xy) dx$. (05 Marks)
- c. Verify Stoke's theorem for $\vec{F} = (2x - y)\hat{i} - yz^2\hat{j} - y^2z\hat{k}$ where S is the upper half surface of the sphere $x^2 + y^2 + z^2 = 1$ C is its boundary. (05 Marks)

OR

- 10 a. Derive Euler's equation in the standard form $\frac{\partial f}{\partial y} - \frac{d}{dx} \left(\frac{\partial f}{\partial y_1} \right) = 0$. (06 Marks)
- b. If $\vec{F} = 2xy\hat{i} + y^2z\hat{j} + xz\hat{k}$ and S is the rectangular parallelepiped bounded by $x = 0, y = 0, z = 0, x = 2, y = 1, z = 3$. Evaluate $\iint_S \vec{F} \cdot \hat{n} ds$. (05 Marks)
- c. Prove that the shortest distance between two points in a plane is along the straight line joining them or prove that the geodesics on a plane are straight lines. (05 Marks)

CBCS SCHEME

USN

--	--	--	--	--	--	--	--	--	--

15EC32

Third Semester B.E. Degree Examination, Dec.2019/Jan.2020 Analog Electronics

Time: 3 hrs.

Max. Marks: 80

Note: Answer FIVE full questions, choosing one full question from each module.

Module-1

- 1 a. Draw the circuit diagram of common Emitter fixed bias configuration. Derive the expression for Z_i , Z_o , A_v using r_e model. (08 Marks)
- b. For the network shown in Fig. Q1 (b), determine Z_i , Z_o , A_v and A_i . Given $h_{ie} = 1.175 \text{ K}\Omega$, $h_{fe} = 120$, $h_{oe} = 20 \mu\text{A/v}$ using approximate hybrid equivalent model. (08 Marks)

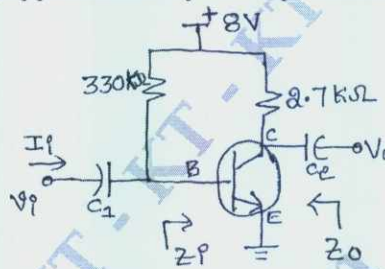

Fig. Q1 (b)

OR

- 2 a. Draw ' r_e ' and ' h '-parameter models for a transistor in common Emitter configuration. Also give relation between ' r_e ' and ' h '-parameter. (05 Marks)
- b. For the circuit shown below, calculate r_e , Z_i , Z_o and A_v , while consider $r_o = \infty$. (08 Marks)

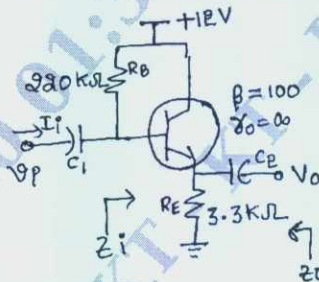

Fig. Q2 (b)

- c. What are the advantages of h-parameters? (03 Marks)

Module-2

- 3 a. Explain the small signal model of the FET. (04 Marks)
- b. Derive the expression for Z_i , Z_o and A_v for FET voltage divider bias circuit. (08 Marks)
- c. Compare JFET and MOSFET. (04 Marks)

OR

- 4 a. Explain the n-channel enhancement type MOSFETs, with their characteristics curves. (08 Marks)
- b. Derive the expression for Z_i , Z_o and A_v for FET self biased configuration (with R_s bypassed). (08 Marks)

Important Note : 1. On completing your answers, compulsorily draw diagonal cross lines on the remaining blank pages.
2. Any revealing of identification, appeal to evaluator and /or equations written eg, 42+8 = 50, will be treated as malpractice.

Module-3

- 5 a. Prove that
Input capacitance is $C_{Mi} = (1 - A_v)C_f$ and
Output capacitance is $C_{MO} = \left(1 - \frac{1}{A_v}\right)C_f$ using miller effect. (08 Marks)
- b. Describe the factors that affect the low frequency response of a BJT-CE amplifier. (08 Marks)

OR

- 6 a. Explain high frequency response of FET amplifier and derive expression for cut off frequencies, defined by input and output circuits (f_{Hi} and f_{Ho}). (08 Marks)
- b. Determine the lower cut off frequency for the network shown in Fig. Q6 (b), using following parameters $g_m = 2 \text{ ms}$, $r_d = \infty \Omega$, $I_{DSS} = 8 \text{ mA}$, $V_P = -4 \text{ V}$, $V_{DD} = 20 \text{ V}$. (08 Marks)

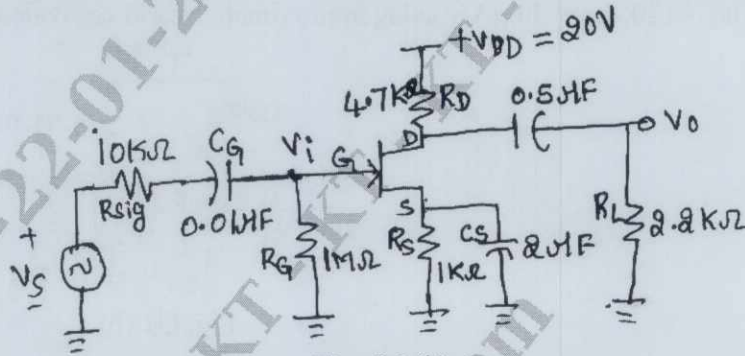

Fig. Q6 (b)

Module-4

- 7 a. With the help of a neat circuit diagram, explain the working of Hartley oscillator. (08 Marks)
- b. The following data for Colpitts oscillator are as follows : $C_1 = 1 \text{ nF}$, $C_2 = 99 \text{ nF}$, $L = 1.5 \text{ mH}$ and $h_{fe} = 110$. Calculate frequency of oscillation for the same. (04 Marks)
- c. Explain the important advantages of a negative feedback amplifier. (04 Marks)

OR

- 8 a. Mention the types of feedback connections. Draw their block diagrams indicating input and output signal. (08 Marks)
- b. Obtain expression for Z_{if} , Z_{of} for a voltage series feedback. (08 Marks)

Module-5

- 9 a. Explain the operation of a class B push-pull amplifier and also show that its efficiency is 78.50%. (08 Marks)
- b. With a neat circuit diagram, explain the operation of a transformer coupled class A power amplifier. (08 Marks)

OR

- 10 a. For a harmonic distortion reading of $D_2 = 0.1$, $D_3 = 0.02$ and $D_4 = 0.01$, with $I_1 = 4 \text{ A}$ and $R_C = 8 \Omega$, calculate the total harmonic distortion, fundamental power and total power. (04 Marks)
- b. What are the classification of power amplifiers, based on the location of Q - point? Discuss them briefly. (08 Marks)
- c. With the help of neat block diagram, explain the working of shunt voltage regulator. (04 Marks)

CBCS SCHEME

USN

--	--	--	--	--	--	--	--	--	--

15EC34

Third Semester B.E. Degree Examination, Dec.2019/Jan.2020 Network Analysis

Time: 3 hrs.

Max. Marks: 80

Note: 1. Answer any FIVE full questions, choosing ONE full question from each module.
2. Missing data, if any, may be suitably assumed.

Module-1

- 1 a. Derive expression for converting star to delta. (08 Marks)
 b. Using Mesh current find V_2 which result a zero current in 4 ohm resistor in the network shown in Fig.Q1(b). (08 Marks)

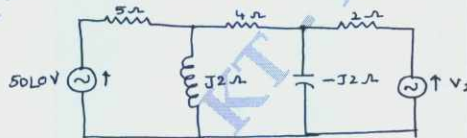

Fig.Q1(b)

OR

- 2 a. For the network of Fig.Q2(a), determine the v_1 and v_2 by nodal analysis. (08 Marks)

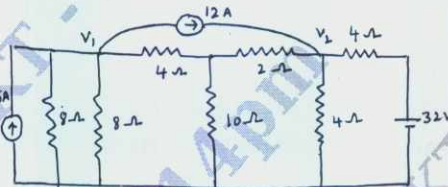

Fig.Q2(a)

- b. Find the current I in 28Ω resistor by Mesh analysis in Fig.Q2(b). (08 Marks)

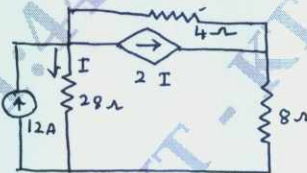

Fig.Q2(a)

Module-2

- 3 a. State and prove superposition theorem. (06 Marks)
 b. Using Milliman's theorem, find I_L through R_L for the network shown in Fig.Q3(b). (04 Marks)

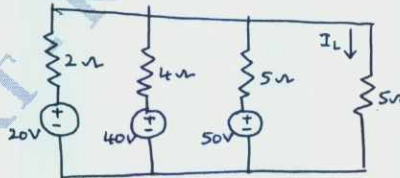

Fig.Q3(b)

- c. Obtain Norton equivalent of the network of Fig.Q3(c) between terminals A and B. (06 Marks)

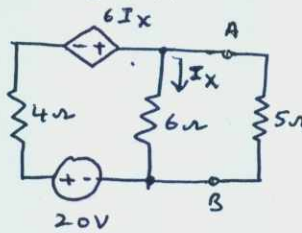

Fig.Q3(c)

Important Note : 1. On completing your answers, compulsorily draw diagonal cross lines on the remaining blank pages.
2. Any revealing of identification, appeal to evaluator and /or equations written eg, 42+8 = 50, will be treated as malpractice.

OR

- 4 a. State maximum power transfer theorem. Prove that $Z_L = Z_0^*$ for AC circuits. (08 Marks)
 b. Verity reciprocity theorem to find value of V_X in the circuit shown Fig.Q4(b). (08 Marks)

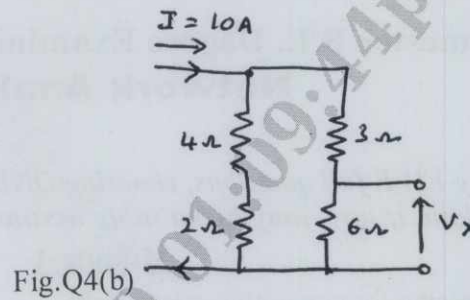

Fig.Q4(b)

Module-3

- 5 a. In the network shown in Fig.Q5(a), K is changed from position a to b at $t = 0$. Solve for i , $\frac{di}{dt}$ and $\frac{d^2i}{dt^2}$ at $t = 0^+$, if $R = 1000\Omega$, $L = 1H$, $C = 0.1\mu F$ and $V = 100V$. Assume that the capacitor is initially uncharged. (08 Marks)

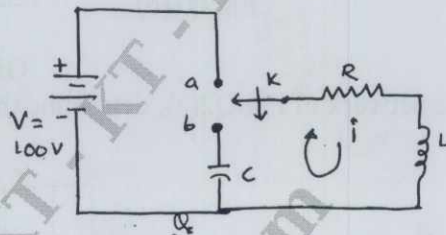

Fig.Q5(a)

- b. Determine the response current $i(t)$ in the circuit shown in Fig.Q5(b) using Laplace transform. (08 Marks)

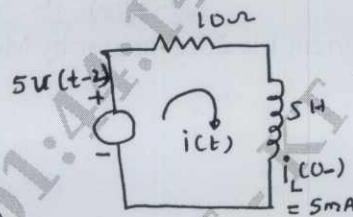

Fig.Q5(b)

OR

- 6 a. Synthesis the waveform shown in Fig.Q6(a) and find the Laplace transform of the periodic waveform. (08 Marks)

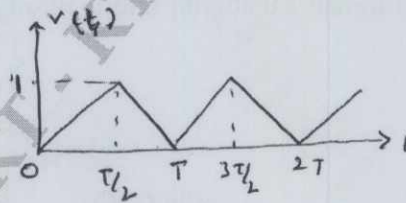

Fig.Q6(a)

- b. Determine v , $\frac{dv}{dt}$ and $\frac{d^2v}{dt^2}$ at $t = 0^+$ when the switch k is opened at $t=0$ in Fig.Q6(b). (08 Marks)

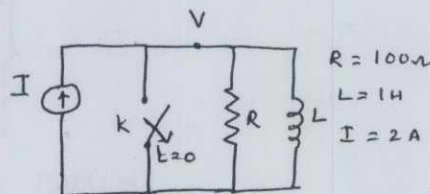
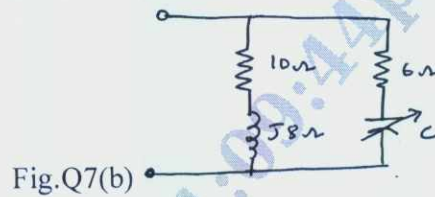

Fig.Q6(b)

Module-4

- 7 a. What is resonance? Show that $f_0 = \sqrt{f_1 f_2}$ for series resonance circuit. (08 Marks)
 b. Find the values of c for which the circuit given in Fig.Q7(b) resonates at 750Hz. (08 Marks)



OR

- 8 a. A series RLC circuit has $R = 4\Omega$, $L = 1\text{mH}$, and $C = 10\mu\text{F}$, calculate Q – factor, bandwidth, resonant frequency and the half power frequencies f_1 and f_2 . (08 Marks)
 b. Derive expression for f_r , Q and bandwidth of a parallel resonant circuit with lossless capacitor in parallel with a coil of resistance R and inductance L . (08 Marks)

Module-5

- 9 a. Derive Y parameters and transmission parameters of a circuit interms of its z -parameters. (08 Marks)
 b. Find the z -parameters for the network shown in Fig.Q9(b). (08 Marks)

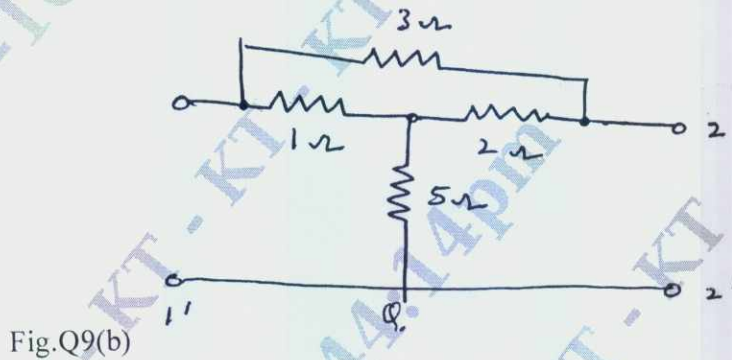

OR

- 10 a. The z parameters of a two port network are $z_{11} = 20\Omega$, $z_{22} = 30\Omega$, $z_{12} = z_{21} = 10\Omega$. Find Y and ABCD parameters. (08 Marks)
 b. Determine Y parameters of the two port network shown in Fig.Q10(b). (08 Marks)

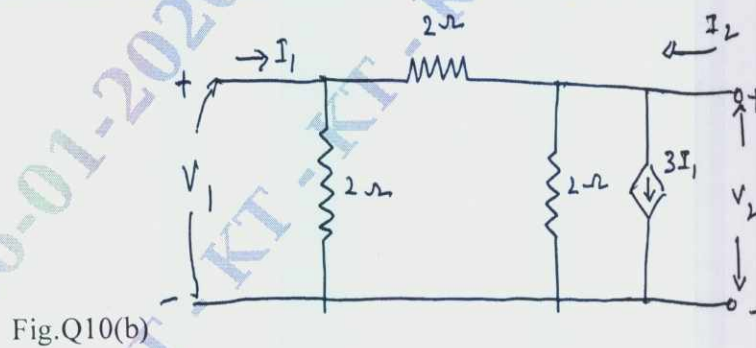

CBCS SCHEME

USN

--	--	--	--	--	--	--	--	--	--

15EC35

Third Semester B.E. Degree Examination, Dec.2019/Jan.2020 Electronic Instrumentation

Time: 3 hrs.

Max. Marks: 80

Note: Answer FIVE full questions, choosing ONE full question from each module.

Module-1

- 1 a. Explain briefly about Gross errors, Absolute error and Relative error in measurements with an example for each. (06 Marks)
- b. Design a multirange ammeter that uses individual shunts for the ranges 0 – 100 mA, 0 – 200 mA and 0 – 500 mA, with a meter of full scale deflection current 100 μ A and resistance 500 Ω . (06 Marks)
- c. Define accuracy, precision, resolution and significant figures in measurements. (04 Marks)

OR

- 2 a. Sketch and explain the operation of a true RMS voltmeter. (06 Marks)
- b. Design a multirange voltmeter that uses series multiplier resistor for the ranges 0 – 5 V, 0 – 50 V and 0 – 100 V with a movement of internal resistance 100 Ω and full scale deflection current 10 mA. (06 Marks)
- c. Sketch and explain the operation of a AC voltmeter using Half Wave rectifier. (04 Marks)

Module-2

- 3 a. With sketch describe the operation of a Dual Scope Integrator type DVM which works on the principle of voltage to time conversion. (08 Marks)
- b. Sketch and explain the operation of staircase Ramp type DVM. (08 Marks)

OR

- 4 a. Sketch the block diagram of a digital multimeter and explain how it measures different parameters like dc and ac voltage, dc current and resistance. (08 Marks)
- b. What is the principle used in measuring frequency of a signal digital technique, with block diagram explain the operation of a digital frequency meter. (08 Marks)

Module-3

- 5 a. With an example of sine wave input signal, explain the principle of displaying a single cycle stationary sine wave on a CRO. (06 Marks)
- b. Give a circuit that generates the horizontal time base signal of CRO and explain its operation. (06 Marks)
- c. Briefly explain how to generate Lissajous figures using CRO and how to measure frequency of an unknown signal. (04 Marks)

OR

- 6 a. With a block diagram, explain the operation of a function generator which generates different shape waveforms. (08 Marks)
- b. Sketch and explain the operation of a pulse generator. What are its requirements? (08 Marks)

Important Note : 1. On completing your answers, compulsorily draw diagonal cross lines on the remaining blank pages.
2. Any revealing of identification, appeal to evaluator and /or equations written eg, 42+8 = 50, will be treated as malpractice.

Module-4

- 7 a. Sketch and explain the operation of a phase sensitive detector to compare the phase of a signal with a reference signal. (08 Marks)
- b. What is the significance of Q of a coil? Give a circuit to measure Q of a coil and explain its operation. What are the factors that affect its measurement? (08 Marks)

OR

- 8 a. Sketch a Wheatstone's Bridge that is used to measure resistance of an unknown resistor. Derive an expression that determines the unknown resistance. (06 Marks)
- b. (i) Sketch a Maxwell's Bridge and derive an expression for determining inductance and resistance of an unknown inductor.
- (ii) What is the value of unknown inductor impedance measured using a Maxwell's bridge at balance with $C_1 = 0.01 \mu\text{F}$, $R_1 = 470 \text{ K}\Omega$, $R_2 = 5.1 \text{ K}\Omega$ and $R_3 = 100 \text{ K}\Omega$? (10 Marks)

Module-5

- 9 a. (i) What are the desired properties of a electrical transducers? (04 Marks)
- (ii) What is the piezo resistive effect in resistance strain gauges? (06 Marks)
- b. Sketch a resistive position transducer and explain its operation to measure displacement. (06 Marks)
- c. With a sketch, explain a method to determine strain using strain gauge in a bridge arrangement. (06 Marks)

OR

- 10 a. Sketch a variable reluctance bridge circuit and explain how it can be used to measure a displacement. (06 Marks)
- b. Sketch the construction of a photo conductive cell and explain how it operates. Give a circuit involving it to operate a light operated relay and briefly explain its operation. (08 Marks)
- c. Write a note on thermister. (02 Marks)

CBCS SCHEME

USN

--	--	--	--	--	--	--	--	--	--

15EC36

Third Semester B.E. Degree Examination, Dec.2019/Jan.2020 Engineering Electromagnetics

Time: 3 hrs.

Max. Marks: 80

Note: Answer any FIVE full questions, choosing ONE full question from each module.

Module-1

- Define electric field intensity and electric flux density and derive the expression for D due to point charge. (05 Marks)
 - Identical point charges of $3\mu\text{C}$ are located at the four corners of the square of 5cm side, find the magnitude of force on any one charge. (08 Marks)
 - On the line described $x = 4\text{m}$, $y = -2\text{m}$ there is uniform charge distribution of density $\rho_l = 10\text{nc/m}$. Find \vec{E} at $(4, 2, -1)\text{m}$. (03 Marks)

OR

- State and explain Coulomb's law of force between two point charges in vector form and mention the units of quantities in the force equation. (08 Marks)
 - Three point charges $Q_1 = -1\mu\text{C}$, $Q_2 = -2\mu\text{C}$ and $Q_3 = -3\mu\text{C}$ are placed at the corners of an equilateral triangle of side 1m, find the magnitude of the electric field intensity at the point bisecting the line joining Q_1 and Q_2 . (08 Marks)

Module-2

- In the region $r \leq 2$, $\vec{D} = \frac{7r^2}{3}\hat{a}_r$ and in the region $r > 2$, $\vec{D} = \frac{120}{r^2}\hat{a}_r$ in spherical coordinate system calculate the charge density. (08 Marks)
 - Derive the expression for continuity of current. (04 Marks)
 - Derive Maxwell's first equation in electrostatic. (04 Marks)

OR

- Obtain the boundary condition at the interface between a dielectric material and a conductor. (08 Marks)
 - State and explain Gauss law in point form. (04 Marks)
 - If the potential field $V = 3x^2 + 3y^2 + 2z^3$ volts, find: i) V ii) E iii) \vec{P} at $P(-4, 5, 4)$. (04 Marks)

Module-3

- State and explain Biot-Savart's law. (05 Marks)
 - Two parallel conducting discs are separated by distance 5mm at $z = 0$ and $z = 5\text{mm}$. If $v = 0$ at $z = 0$ and $v = 100\text{v}$ at $z = 5\text{mm}$, find the charge densities on the discs. (05 Marks)
 - Using Poisson's equation obtain the expression for the junction potential in a p-n junction. (06 Marks)

OR

- 6 a. Derive Laplace and Poisson's equation starting from the Gauss's law and also write Laplace's equation in Cartesian, cylindrical and spherical coordinate system. (08 Marks)
- b. Evaluate both sides of the Stoke's theorem for the field $\vec{H} = 6xy \hat{a}_x - 3y^2 \hat{a}_y$ A/m and the rectangular path around the region $2 \leq x \leq 5, -1 \leq y \leq 1, z = 0$ let the positive direction of \vec{ds} be \hat{a}_z . (08 Marks)

Module-4

- 7 a. Obtain the expression for reluctance in a series of magnetic circuits. (04 Marks)
- b. A point charge of $Q = -1.2C$ has velocity, $\vec{V} = (5\hat{a}_x + 2\hat{a}_y - 3\hat{a}_z)$ m/s. Find the magnitude of the force exerted on the charge if,
- i) $\vec{E} = -18\hat{a}_x + 5\hat{a}_y - 10\hat{a}_z$ v/m
- ii) $\vec{B} = -4\hat{a}_x + 4\hat{a}_y + 3\hat{a}_z$ T
- iii) Both are present simultaneously. (08 Marks)
- c. Two infinitely long straight conductors are located at $x = 0, y = 0$ and $x = 0, y = 10$ m. Both carry current of 10A in positive \hat{a}_z direction. Determine force experienced per meter between them. (04 Marks)

OR

- 8 a. State and explain Lorentz force equation. (08 Marks)
- b. Find the magnetization in a magnetic material where,
- i) $\mu = 1.8 \times 10^5$ (H/m) and $M = 120$ (A/M)
- ii) $\mu_r = 22$, there are 8.3×10^{28} atoms/m³ and each atom has a dipole moment of 4.5×10^{-27} (A/m²) and
- iii) $B = 300\mu$ T and $\chi_m = 15$. (08 Marks)

Module-5

- 9 a. Starting from Maxwell's equation derive wave equation in \vec{E} and \vec{H} for a uniform plane wave travelling in free space. (08 Marks)
- b. A homogeneous material has $\epsilon = 2 \times 10^9$ F/m and $\mu = 1.25 \times 10^{-6}$ H/m and $\sigma = 0$. Electric field intensity is given as $\vec{E} = 400 \cos(10^9 t - kz) \hat{a}_n$ v/m, if all the fields vary sinusoidally find \vec{D} , \vec{B} and \vec{H} . Also find k using Maxwell's equations. (08 Marks)

OR

- 10 a. List Maxwell's equation in point form and integral form. (06 Marks)
- b. A 15GHZ plane wave travelling in a medium has an amplitude $E_0 = 20$ v/m. Find phase velocity, propagation constant and impedance. Assume $\epsilon_r = 2$ and $\mu_r = 5$. (06 Marks)
- c. 8 watts/m² is the pointing vector of a plane wave travelling in free space. What is the average energy density? (04 Marks)

CBCS SCHEME

USN

--	--	--	--	--	--	--	--	--	--

15MATDIP31

Third Semester B.E. Degree Examination, Dec.2019/Jan.2020 Additional Mathematics – I

Time: 3 hrs.

Max. Marks: 80

Note: Answer any FIVE full questions, choosing ONE full question from each module.

Module-1

- 1 a. Find modulus and amplitude of $1 - \cos\theta + i \sin\theta$. (05 Marks)
- b. Express $\frac{3+4i}{3-4i}$ in $a+ib$ form. (05 Marks)
- c. Find the value of ' λ ' so that the points $A(-1, 4, -3)$, $B(3, 2, -5)$, $C(-3, 8, -5)$ and $D(-3, \lambda, 1)$, may lie on one plane. (06 Marks)

OR

- 2 a. Find the angle between the vectors $\vec{a} = 5\hat{i} - \hat{j} + \hat{k}$ and $\vec{b} = 2\hat{i} - 3\hat{j} + 6\hat{k}$. (05 Marks)
- b. Prove that $\begin{bmatrix} \vec{a} \times \vec{b} & \vec{b} \times \vec{c} & \vec{c} \times \vec{a} \end{bmatrix} = \begin{bmatrix} \vec{a} & \vec{b} & \vec{c} \end{bmatrix}^2$. (05 Marks)
- c. Find the real part of $\frac{1}{1 + \cos\theta + i \sin\theta}$. (06 Marks)

Module-2

- 3 a. Obtain the n^{th} derivative of $\sin(ax + b)$. (05 Marks)
- b. Find the pedal equation of $r^n = a^n \cos n\theta$. (05 Marks)
- c. If $u = \frac{yz}{x}$, $v = \frac{zx}{y}$, $w = \frac{xy}{z}$, show that $\frac{\partial(u, v, w)}{\partial(x, y, z)} = 4$. (06 Marks)

OR

- 4 a. If $u = \log\left(\frac{x^4 + y^4}{x + y}\right)$ show that $x \frac{\partial u}{\partial x} + y \frac{\partial u}{\partial y} = 3$. (05 Marks)
- b. If $u = f(x - y, y - z, z - x)$, show that $\frac{\partial u}{\partial x} + \frac{\partial u}{\partial y} + \frac{\partial u}{\partial z} = 0$. (05 Marks)
- c. If $y = a \cos(\log x) + b \sin(\log x)$, show that $x^2 y_{n+2} + (2n+1)xy_{n+1} + (n^2+1)y_n = 0$ (06 Marks)

Module-3

- 5 a. Evaluate $\int_0^{\pi} x \sin^8 x dx$. (05 Marks)
- b. Evaluate $\int_0^1 x^2 (1-x^2)^{3/2} dx$. (05 Marks)
- c. Evaluate $\int_{-c}^c \int_{-b}^b \int_{-a}^a (x^2 + y^2 + z^2) dz dy dx$. (06 Marks)

OR

- 6 a. Evaluate $\int_0^1 \int_x^{\sqrt{x}} xy \, dy \, dx$. (05 Marks)
- b. Evaluate $\int_0^1 \int_0^1 \int_0^1 (x+y+z) \, dx \, dy \, dz$. (05 Marks)
- c. Evaluate $\int_0^{\infty} \frac{x^4}{(1+x^2)^4} \, dx$. (06 Marks)

Module-4

- 7 a. If $\vec{r} = (t^2 + 1)\hat{i} + (4t - 3)\hat{j} + (2t^2 - 6t)\hat{k}$, find the angle between the tangents at $t = 1$ and $t = 2$. (05 Marks)
- b. If $\vec{r} = e^{-t}\hat{i} + 2\cos 3t\hat{j} + 2\sin 3t\hat{k}$, find the velocity and acceleration at any time t , and also their magnitudes at $t = 0$. (05 Marks)
- c. Show that $\vec{F} = (y+z)\hat{i} + (z+x)\hat{j} + (x+y)\hat{k}$ is irrotational. Also find a scalar function ' ϕ ' such that $\vec{F} = \nabla\phi$. (06 Marks)

OR

- 8 a. Find the unit normal vector to the surface $x^2y + 2xz = 4$ at $(2, -2, 3)$. (05 Marks)
- b. If $\vec{F} = xz^3\hat{i} - 2x^2yz\hat{j} + 2yz^4\hat{k}$ find $\nabla \cdot \vec{F}$ and $\nabla \times \vec{F}$ at $(1, -1, 1)$. (05 Marks)
- c. If $\frac{d\vec{a}}{dt} = \vec{w} \times \vec{a}$ and $\frac{d\vec{b}}{dt} = \vec{w} \times \vec{b}$, then show that $\frac{d}{dt}(\vec{a} \times \vec{b}) = \vec{w} \times (\vec{a} \times \vec{b})$. (06 Marks)

Module-5

- 9 a. Solve $\sec^2 x \tan y \, dx + \sec^2 y \tan x \, dy = 0$. (05 Marks)
- b. Solve $(y^3 - 3x^2y) \, dx + (3xy^2 - x^3) \, dy = 0$. (05 Marks)
- c. Solve $\frac{dy}{dx} + \frac{y}{x} = xy^2$. (06 Marks)

OR

- 10 a. Solve $\frac{dy}{dx} + y \cot x = \cos x$. (05 Marks)
- b. Solve $x^2 y \, dx - (x^3 + y^3) \, dy = 0$. (05 Marks)
- c. Solve $y(x+y) \, dx + (x+2y-1) \, dy = 0$. (06 Marks)
